



**CLEAN DEVELOPMENT MECHANISM  
PROJECT DESIGN DOCUMENT FORM (CDM-PDD)  
Version 03 - in effect as of: 28 July 2006**

**CONTENTS**

- A. General description of project activity
- B. Application of a baseline and monitoring methodology
- C. Duration of the project activity / crediting period
- D. Environmental impacts
- E. Stakeholders' comments

**Annexes**

- Annex 1: Contact information on participants in the project activity
- Annex 2: Information regarding public funding
- Annex 3: Baseline information
- Annex 4: Monitoring plan

**SECTION A. General description of project activity****A.1 Title of the project activity:**

&gt;&gt;

34MW bagasse based cogeneration project in Uttar Pradesh, India  
Version 01  
30/01/2007

**A.2. Description of the project activity:**

&gt;&gt;

The proposed project activity is a 7000TCD Greenfield project in the state of Uttar Pradesh by Mankapur Chini Mills (MCM). The project is to make use of the sugar mill-generated bagasse to generate steam and electricity for internal use and to export the surplus power to the Uttar Pradesh Power Corporation Limited (UPPCL) grid. The project activity would be capable of generating 34MW power and after meeting the internal captive power requirement for the unit it will export the surplus power to the grid. It will be therefore a supplement to traditional fossil fuel based power plants in the northern region grid. As the project utilizes only bagasse (a renewable biomass) for the generation of electricity it will not only cut down the emission rate but also help conserving non-renewable fossil fuel.

The project activity is unique in India as it involves high efficiency boilers, which optimises the energy produced per unit of bagasse burned. While many sugar mills burn their bagasse wastes, very few mills sell electricity to a state grid and few bagasse cogeneration power plants have high-pressure boiler systems (87kg/cm<sup>2</sup>). The project activity is highly replicable as the country's sugar mills produce vast quantities of bagasse wastes. These could be far more efficiently burned to generate energy for on and off-site use while also reducing grid-based GHG emissions, which result from the country's overwhelming (70%) dependency on fossil fuel.

The project activity involves the installation of two boilers of a 90TPH capacity with outlet steam parameters of 87 ata and 515±5Deg.C; one extraction cum condensing turbo-generator of 22MW and one 12MW back pressure turbo-generator. The gross energy generated during the season period is expected to be 33.9 MW of which 11.3 MW would be used for the captive use and the remaining 22.6 MW would be exported to the grid whilst during the off season the captive requirement would be around 3.45 MW and about 17.32 MW would be interfaced with the Northern region electricity grid.

The power generation in the plant will be at an 11kV level. The internal consumption requirements for the auxiliaries and the equipment of the sugar plant and the cogeneration plant will be met by stepping down the voltage level to 415 V. The exportable power will be stepped up to 132 kV and paralleled with the UPPCL grid at 132 kV. The paralleling with the UPPCL grid will be done at the UPPCL sub-station at Mankapur, which is about 8 km from the plant.

**Project's contribution to sustainable development**

The project activity contributes to the 'Sustainable Development of India' in the following ways;



- The project activity is a renewable energy power project, which will use bagasse waste generated from sugar mill as a fuel for power generation and will export clean power to a grid.
- This electricity generation would substitute the power generation by carbon intensive UPPCL grid (northern region grid), which uses carbon emissive conventional fuels like coal, diesel/oil, natural gas etc. Thus, the project activity will reduce the CO<sub>2</sub> emissions and also save the conventional fuel.
- The Indian economy is highly dependent on “coal” as a fuel to generate energy and for production processes. Thermal power plants are the major consumers of coal in India, and yet the basic electricity needs of a large section of the population are not always met. This results in excessive demands for electricity and places immense stress on the environment. Changing coal consumption patterns will require a multi-pronged strategy focusing on demand, reducing wastage of energy and the optimum use of Renewable Energy (RE) sources. Since this project activity utilizes a renewable energy source, it will positively contribute to the reduction in the (demand) use of finite natural resource like coal/ oil, minimizing depletion and increasing its availability to other important processes. The project activity, by feeding clean power to a grid, will eliminate an equivalent carbon dioxide (CO<sub>2</sub>) emission that would be the result of the production of the electricity necessary to cater to the electricity requirement. Therefore this project activity has excellent environmental benefits in terms of reduction in carbon emissions and coal resource conservation.
- This project activity is in the rural setting and will contribute to the Environmental & Social issues locally and globally by:
  - ✚ The export of power, thereby eliminating the generation of same quantity of power using conventional fuel;
  - ✚ Conserving and displacing coal, a non-renewable natural resource;
  - ✚ Increasing the diversity and reliance of local energy resources;
  - ✚ Reducing GHG emissions (Carbon Dioxide) through the avoidance of fossil fuel grid electricity generation;
  - ✚ Contributing to a small increase in the local employment in the area of skilled & unskilled jobs for the operation and the maintenance of the equipment

The project imparts a direct positive impact in improving the quality of life of the local population as it provides an inflow of funds, additional employment, technological and managerial capacity building etc. The following paragraphs illustrate briefly how the project activity contributes to the four pillars (indicators) of the sustainable development of India:

### **Social aspects**

The location of the project in rural setting contributes towards poverty alleviation by generating both direct and indirect employment. The project makes a significant contribution to development as any rurally based industry in India provides an important source of direct employment in the surrounding area. Uttar Pradesh, where the plant is located, is one of the most populous states in India with 88% of the population located in rural areas. Therefore the provision of direct employment will provide a much-needed alternative to those situated in the locality of the plant. The sugar factory is expected to employ



more than 50 in the power plant, a number of whom will be skilled boiler and turbine operators and engineers. Furthermore, the project will help bridge the gap in the demand and supply of electricity at a local and national level.

### **Economic aspects**

The project's investment is to the tune of Rs. 980 million in addition to which there will be continuous inflow of funds considering CDM revenues. In the absence of the project such an inflow of funds to the region was not envisaged.

### **Environmental aspects**

The project activity is a renewable energy cogeneration project, which uses mill-generated bagasse of sugar mill as a fuel for power generation. The CO<sub>2</sub> emissions of the combustion process due to burning of bagasse are consumed by the plant species, representing a cyclic process. The bagasse generation, storage and usage is governed by established system and channel to ensure no resource degradation. The plant uses state of the art control systems to minimize pollution like electrostatic precipitators, full fledged effluent treatment system etc to control the air and water discharges. Since this project activity generates green power, it has positively contributed towards the reduction in (demand) use of finite natural resource like coal/oil, minimizing depletion and in turn increasing its availability to other important purposes. Therefore this project activity has excellent environmental benefits in terms of reduction in carbon emissions and coal resource conservation.

### **Technological aspects**

The project activity uses one of the most environmental friendly technologies of cogeneration in the renewable energy sector. The project comprises of 180 tons per hour (TPH) capacity steam generator with the outlet steam parameters of 87kg/cm<sup>2</sup> and 515°C, with 34MW capacity turbine generator set of one double extraction cum condensing (DEC) type turbine and one back pressure turbine. The higher steam parameters result in higher annual savings of fuel per annum when compared to lesser steam parameters like the 21kg/cm<sup>2</sup> prevalent in the country.

#### **A.3. Project participants:**

>>

<b>Name of Party involved (*) ((host) indicates a host Party)</b>	<b>Private and/or public entity(ies) project participants (*) (as applicable)</b>	<b>Kindly indicate if the Party involved wishes to be considered as project participant (Yes/No)</b>
Ministry of Environment and Forest, Government of India	Mankapur Chini Mills (Private entity, project participant)	No

#### **A.4. Technical description of the project activity:**

##### **A.4.1. Location of the project activity:**

>>



**A.4.1.1. Host Party(ies):**

>>  
India

**A.4.1.2. Region/State/Province etc.:**

>>  
Uttar Pradesh State

**A.4.1.3. City/Town/Community etc:**

>>  
Gonda District, Mankapur Tehsil, Datauli Village

**A.4.1.4. Detail of physical location, including information allowing the unique identification of this project activity (maximum one page):**

>>  
The CDM project is a co-generation power facility utilizing the mill-generated bagasse situated in the district of Gonda of the Uttar Pradesh state. Gonda District is well connected to important towns and cities of the country and nearby area. The physical location of the Mankapur project is 27.28°N Latitude and 82.01°E Longitude.

The location map of the project is furnished below:



Uttar Pradesh State (marked in yellow) within India, Gonda District (No: 34) within UP



Location of the project site in Mankapur village of Gonda District

**A.4.2. Category(ies) of project activity:**

&gt;&gt;

The present project activity will fall under the sectoral scope 1: Energy Industries (renewable / non-renewable sources)

**A.4.3. Technology to be employed by the project activity:**

&gt;&gt;

The project is a grid-connected bagasse based cogeneration power plant with a high-pressure steam turbine configuration. The plant is designed to operate two boilers of 90 TPH capacity with outlet steam configuration of 87 ata and  $515 \pm 5^\circ\text{C}$ , one extraction cum condensing turbo-generator of 22MW and one 12MW back pressure turbo-generator using bagasse as the fuel. Both boilers and turbo-generators will meet the entire process steam and power requirement for the sugar plant.

The proposed cogeneration project aims at significantly improving the energy efficiency of the sugar factory, enabling the plant to generate power from its cane crushing operations for its in-house requirements and export its surplus power to the grid. Energy efficiency and the export of power is made feasible by the employment of high pressure and high temperature steam cycles and by the utilization of the surplus bagasse to produce more steam and hence more electricity.

The plant operates around 165 days during the crushing season with the balance of about 65 off-season days. The cogeneration plant will operate during the off-season with the saved bagasse from the seasonal operation of the MCM sugar plant.



The bagasse generation in the plant would be 87.6 TPH out of this about 1.6 TPH would be used for the mixing with clarifier mud for vacuum filtering and another 1.03 TPH would be set aside as a windage and transportation loss. Hence about 84.97 TPH of bagasse will be available for the energy generation. During the season period the bagasse consumption in the boiler would be 71 TPH so every hour the net bagasse saved would be 13.97 TPH. For 165 days of season operation the net quantity of bagasse saved would be 49870 MT for off-season operations along with it the plant also procure about 80000 MT of the bagasse from the babnan unit for its operation during the off-season. However the project will not claim any CER for the procured bagasse during the off-season.

The cogeneration plant and equipment will consist of two boilers, backpressure and extraction cum condenser type turbo-generators, a cooling water system, a DM water system, a condensation system, a compressed air system and an electrical system consisting of switch gears, LT distribution panels, a step up transformer to export the power, step down transformers to meet the in-house power requirement of the sugar and power plant, an outdoor switchyard equipment, etc.

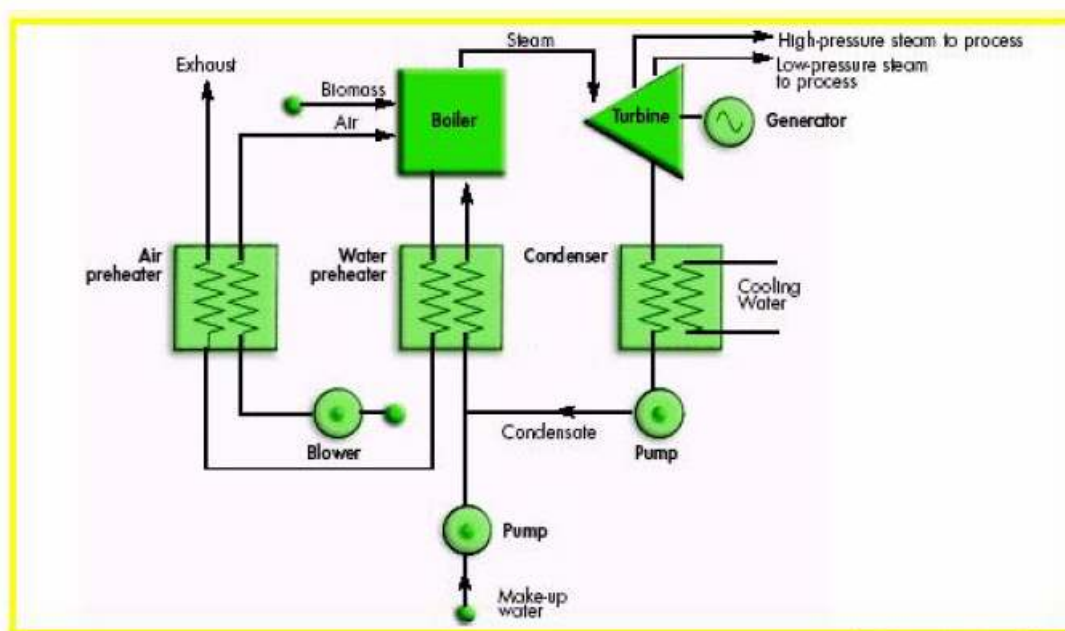

Source: Williams and Larson, 1993

The plant is designed with all other auxiliary plant systems like:

- A bagasse handling system with storage and processing arrangements;
- High pressure feed water heaters;
- An ash handling system;
- Water treatment plants;
- A Compressed air system;
- An air conditioning system;
- Main steam, medium pressure and low pressure steam systems;
- A fire protection system;



- Water systems which include a raw water system, a circulating water system, a condensation system, a de-mineralised water system and service with potable water;
- The electrical system for its successful operation

**A.4.4 Estimated amount of emission reductions over the chosen crediting period:**

&gt;&gt;

The total emission reductions from the project throughout the first crediting period (7 years) are expected to be as under:

Years	Annual estimation of emission reductions in tonnes of CO <sub>2</sub> e
August 2006	42,497
2007	1,01,993
2008	1,01,993
2009	1,01,993
2010	1,01,993
2011	1,01,993
2012	1,01,993
Jan 2013 – July 2013	59,496
For the first crediting period of 7 years (tCO <sub>2</sub> e)	7,13,948

**A.4.5. Public funding of the project activity:**

&gt;&gt;

Not applicable as no funding from Annex 1 based institutions have been availed of.



**SECTION B. Application of a baseline and monitoring methodology****B.1. Title and reference of the approved baseline and monitoring methodology applied to the project activity:**

&gt;&gt;

The project activity follows the recently approved consolidated baseline methodology ACM0006/version 04, EB27, “Consolidated baseline methodology for grid-connected electricity generation from biomass residues”.

**B.2 Justification of the choice of the methodology and why it is applicable to the project activity:**

&gt;&gt;

ACM0006 version 04 is applicable to grid connected and biomass residue based electricity generation project activities, including cogeneration plants. MCM project activity is appropriate to this methodology because the project activity is grid connected electricity generation from bagasse (renewable biomass).

According to the chosen baseline methodology, the proposed Co-generation project complies with the applicability criteria:

“The installation of a new biomass power generation plant at a site where currently no power generation occurs (**Greenfield power projects**)”

The project activity is a Greenfield power generation project at a site where currently no power generation occurs.

**No other biomass types than biomass residues are used in the project plant and these biomass residues are the predominant fuel used in the project plant:**

Bagasse is a residue from sugar industry is the only type of biomass residue that is used as fuel in the project activity. No other biomass types other than bagasse are used in the project plant.

**The implementation of the project shall not result in an increase of the processing capacity:**

The implementation of the project activity has no direct/indirect effect on the bagasse production in the facility. The bagasse production is guided by sugar production requirements.

**The biomass stored at the project facility should not be stored for more than one year:**

A small portion of the bagasse of the plant is stored at the plant premises for use in the non-crushing period. This quantity of bagasse is not stored at the project facility for more than one year.

**No significant energy quantities, except for the transportation of the biomass, are required to prepare the biomass residues for fuel combustion:**

No significant energy quantities are required for fuel preparation.

Hence, the project activity fulfils all the applicability criteria of the methodology ACM0006.

**B.3. Description of the sources and gases included in the project boundary**



&gt;&gt;

As mentioned in the methodology, the boundary for which the GHG emissions are to be counted must take into account all sources of GHG emissions, that is the emissions from the transportation of biomass, from the on-site use of fossil fuels, from fossil fuel fired power plants connected to the grid and from fossil fuel based heat generation.

	Source	Gas	Included?	Justification / Explanation
Baseline	Grid electricity generation	CO <sub>2</sub>	Yes	Main emission source
	Heat generation	CO <sub>2</sub>	No	The heat generated from the project activity claims no emission reductions.
	Uncontrolled burning or decay of surplus biomass	CH <sub>4</sub>	No	Emissions from uncontrolled burning or decay of surplus biomass are not included in the application of the methodology to the particular baseline scenario identified and therefore these sources are not accounted for in project activity emissions.
Project Activity	On-site fossil fuel consumption due to the project activity	CO <sub>2</sub>	No	No fossil fuel combusted at the project site.
	Off-site transportation of biomass	CO <sub>2</sub>	No	All biomass will be utilized from the sugar mill situated next to the project site.
	Combustion of biomass for electricity and / or heat generation	CH <sub>4</sub>	No	If the baseline accounts for emissions from these sources then they must be accounted for in project activity emissions, we have not accounted for these in the baseline and therefore exclude them from the analysis of project activity sources.
	Biomass storage	CH <sub>4</sub>	No	Since biomass is not stored for more than one year, the emission sources are not accounted in for project activity emissions

**B.4. Description of how the baseline scenario is identified and description of the identified baseline scenario:**

&gt;&gt;

The determination of the baseline scenario requires us to consider the most conservative baselines for the generation of power, the generation of heat and the use of biomass.

Power baselines:

	Alternatives as per ACM 0006	Description



P1	The proposed project activity not undertaken as a CDM	It is not a credible baseline scenario as without the registration of the CDM project it would not occur.
P2	<b>The proposed project activity (installation of a power plant), fired with the same type of biomass but with a lower efficiency of electrical generation (e.g. an efficiency that is common practice in the relevant industry sector)</b>	<b>This is a credible baseline as it would be possible for the plant to install a lower efficiency system using just bagasse as a fuel.</b>
P3	The generation of power in an existing plant, on-site or nearby the project site, using only fossil fuels	It may be ruled out as setting up a similar sized fossil fuel power plant to supply to the grid is not feasible given the scale of the plant nor is it part of the core business of the company.
P4	<b>The generation of power in existing and/or new grid-connected power plants</b>	<b>This would also be a credible baseline – the generation of power in existing and/or new grid connected plants – as the power from the project activity will be fed into the grid and is thus expected to displace power from existing and planned capacity additions of the northern region grid.</b>
P5	The continuation of power generation in an existing power plant, fired with the same type of biomass as (co-) fired in the project activity, and implementation of the project activity, not undertaken as a CDM project activity, at the end of the lifetime of the existing plant	This may be ruled out as the new power plant is not a replacement for existing power generating units and is an addition to the capacity of power plants generating electricity from bagasse.
P6	The continuation of power generation in an existing power plant, fired with the same type of biomass as (co-)fired in the project activity and, at the end of the lifetime of the existing plant, replacement of that plant by a similar new plant	This may also be ruled out as the new power plant is not a replacement for existing power generating units and is an addition to the capacity of power plants generating electricity from bagasse.



## Heat baselines:

	Alternatives as per ACM 0006	Description
H1	The proposed project activity not undertaken as a CDM project activity	This would be ruled out because without consideration of the CDM registration the project would not occur
<b>H2</b>	<b>The proposed project activity (installation of a cogeneration power plant), fired with the same type of biomass but with a different efficiency of heat generation (e.g. and efficiency that is common practice in the relevant industry sector)</b>	<b>This is the most realistic interpretation as the common practice in the region is to use low efficient energy generating units as compared to that of the project activity.</b>
H3	The generation of heat in an existing cogeneration plant, on-site or nearby the project site, using only fossil fuels	Not Applicable (NA) as the project activity generate steam to the adjoining sugar plant
H4	The generation of heat in boilers using the same type of biomass residues	This could also one of the alternatives.
H5	The continuation of heat generation in an existing power plant, fired with the same type of biomass as in the project activity, and implementation of the project activity, not undertaken as a CDM project activity, at the end of the lifetime of the existing plant	As the project is a Greenfield project this is not a credible alternative.
H6	The generation of heat in boilers using fossil fuels	NA as the project activity generates LP steam to the sugar plant.
H7	The use of heat from external sources, such as district heat	NA as the project activity generates LP steam to the sugar plant.
H8	Other heat generation technologies (e.g. heat pumps or solar energy)	NA as the project activity generates LP steam to the sugar plant.

## Biomass baselines

	Alternatives as per ACM 0006	Description
B1	The biomass is dumped or left to decay or burned in an uncontrolled manner without utilizing it for energy purposes	As the bagasse is predominantly used for heat generation the scenario could be eliminated.
<b>B2</b>	<b>The biomass is used for heat and/or electricity generation at the project site.</b>	<b>This would be the most realistic alternative that in the absence of the project activity the biomass would be used for heat/power generation but with lower efficiency.</b>
B3	The biomass is used for power generation, including cogeneration, in other existing or new grid connected power plants	As the fuel is also used for captive heat and power purposes this could be eliminated.



B4	The biomass is used for heat generation in other existing or new boilers at other sites	Same as B3.
B5	The biomass is used for other energy purposes, such as the generation of bio fuels.	No such technology is available from the feedstock of the project activity exists in the host country.
B6	The biomass is used for non-energy purposes, e.g. as fertilizer or as feedstock in processes	Most of the generated biomass would be used for energy purposes only. Some portion of the biomass is used as feedstock by the local paper industry, but on account of surplus availability of bagasses, this is not considered to be a major issue.

**From the above analysis the suitable baseline scenario relates to the project activity is scenario 4 – P2 & P4, H2 and B2.** The baseline scenario is therefore the new power plant would be established to provide electricity and steam to the adjacent sugar factory. In absence of this proposed project, the biomass generated would be combusted in a less efficient manner to provide enough power for the operation of the sugar factory.

**B.5. Description of how the anthropogenic emissions of GHG by sources are reduced below those that would have occurred in the absence of the registered CDM project activity (assessment and demonstration of additionality): >>**

As per the selected methodology, to prove that the project is not part of the baseline is demonstrated using the Tool for the demonstration and assessment of additionality, version 02, 28th November 2005.

**Step 0: Preliminary screening based on the starting date of the project activity.**

The project is expected to start generating electricity from 15/08/2006. The crediting period is expected to start thereafter. Since the project participants do not wish to have the crediting period start prior to the registration of their project activity the Step 0 is satisfied.

**Step 1: Identification of alternatives to the project activity consistent with current laws and regulations.**

*Sub-step 1a. Define alternatives to the project activity:*

The following alternatives are consistent with the current laws and regulations of the host country: As per ACM 0006, the alternatives should be identified as per the baseline case

**Option A:**

P2 and P4: The proposed project activity (installation of a power plant), fired with the same type of biomass but with a lower efficiency of electrical generation (e.g. an efficiency that is common practice in the relevant industry sector) and the generation of power with existing and / or new grid connected power plants



In the absence of the project activity, power would have been generated for one part in the plant, but in a less effective manner than in the proposed project, using a low-pressure boiler, and for another part, by the power plants in the Northern regional electricity grid. This is compliant with legal and regulatory requirements and therefore suitable to be considered as the baseline for the project activity. The two identified alternatives are described separately

*1. Generation of power with existing/new grid connected power plants.*

Power generation is the single most significant activity that results in anthropogenic greenhouse gas emissions, especially carbon di-oxide. The main reason for this is the use of carbon intensive fossil fuels in power generation. These include sub bituminous coal, brown coal/lignite, HFO, diesel and natural gas. In India, like in many developing countries, coal is the mainstay of fuels used for power generation. The overall nationwide mix of thermal to hydroelectric power has deteriorated in the past five decades and stands currently at around 74:26 (Ministry of Power Annual Report 2003-04). There are plans to augment this capacity, which mainly comprises thermal power using fuels like coal, natural gas and some hydropower projects. As a whole the Northern regional power grid exhibits a high composition of carbon intensive fuels with more than 74% of the generated power.

As per the plan of the GoI, an additional 100,000 MW of capacity is expected by 2012, of which 30% is expected through hydropower. 33 % of these installations are expected to take place in the Uttaranchal region, which falls under the Northern region. As per the load generation scenario presented by POWER GRID by early 11<sup>th</sup> plan (2008-09), the Northern and the Western regions will have a deficit of 8000 MW each, whereas the Eastern and North-eastern regions will have a surplus of 10,500 MW and 3000 MW respectively. Considering that, to cater the need of the Northern region, the power has to be transported from the Eastern region, a solution that is fossil fuel intensive and that is not favoured by the policies. The surplus projected in the Northeastern region is still under construction. Under this scenario, the most conservative baseline would be that in the absence of the project activity, the power that is supposed to be exported from this unit would be generated elsewhere in the region and thus be based on fossil fuel.

In this context of growing energy needs, the generation of power through the proposed project seems to be a good option, as it does not generate greenhouse gases. The power generated and fed to the grid will help in replacing the many units that would otherwise have been supplied by carbon intensive fuel sources on the margin. In the absence of the proposed project, either these carbon intensive sources (most probably the thermal power supplied by the central power PSUs) would have been despatched or the power requirement would have been left unmet.

The proposed project activity is displacing grid electricity, which is fed by both fossil, and non-fossil fuel based generation sources. Keeping in mind the electricity scenario presented above, the entire Northern Region Electricity Grid (NREB) system with its expansion plans, generation and investment trends are taken into consideration when identifying the baseline scenario.

It was found that the grid system is highly carbon intensive due to the major share of power coming from coal, lignite and gas based thermal power plants. As per the latest records of power generation, the share of thermal power is around 74.4%, Hydro 21.32% and Nuclear 4.33%. Presently, the electricity supply position in the region is at a deficit by 11.93 % (peak) and energy shortage by 9.60%. Further, as per the 16<sup>th</sup> Electric Power Survey by Central Electricity Authority, the growth in the energy requirement is



around 6.9% till 2017. About 27,000<sup>1</sup> MW shall be added in order to meet the present energy demand and the growth in the energy requirements, which means the mobilisation of huge financial resources into the power sector. The capacity addition planned at present will not be sufficient to meet the energy demand and it is most likely that all power generating plants will be in operation during the crediting period. An analysis of the past data indicates that the planned capacity could never be achieved in the power sector in the country. The last two five-year plans (the eighth and the ninth plan) have a deficit of 46 % and 53 % respectively, in regard of the targeted capacity addition.

In the absence of the proposed project, deficit power may be met from the fossil fuel based power plants.

**Table B.2.** Installed capacity mix and energy supply position in the Northern Region.

State	Thermal				Nuclear	Total	Energy Deficit	Peak Deficit
	Hydro	Coal	Gas/Dirsel	Total			MU/day	MW
Delhi	0	1087.5	612.4	1699.9	0	1699.9	0.43	68
Haryana	62.4	1525	430	2017.4		2017.4	4.2	310
Himachal Pradesh	4568.6	0	0	4568.6		4568.6	0.23	40
Jammu & Kashmir	1471.8	0	175	1646.8		1646.8	5.84	122
Punjab	2546	2120	0	4666		4666	6.38	1132
Rajasthan	430	2295	526.8	3251.8	740	3991.8	1.37	180
Uttar Pradesh	516.6	9629	1469	11614.6	440	12054.6	27.52	1677
Uttaranchal	1603.9	0	0	1603.9		1603.9	0.35	55
Chandigarh	0	0	2	2		2	0	0
source (Energy & Peak Deficit):				Northern Region Electricity Board Annual Report 2004-2005				
Source: <a href="http://www.cea.nic.in">www.cea.nic.in</a>								

State	Thermal				Nuclear	Total	Energy Deficit	Peak Deficit
	Hydro	Coal	Gas/Dirsel	Total			%	%
Delhi	0.00	63.97	36.03	100.0	0.00	100	0.75	1.91
Haryana	3.09	75.59	21.31	100.0	0.00	100	7.00	7.89
Himachal Pradesh	100.00	0.00	0.00	100.0	0.00	100	2.33	5.76
Jammu & Kashmir	89.37	0.00	10.63	100.0	0.00	100	23.40	9.04
Punjab	54.56	45.44	0.00	100.0	0.00	100	7.12	16.88
Rajasthan	10.77	57.49	13.20	81.5	18.54	100	1.68	3.86
Uttar Pradesh	4.29	79.88	12.19	96.3	3.65	100	19.35	21.04
Uttaranchal	100.00	0.00	0.00	100.0	0.00	100	2.77	6.43
Chandigarh	0.00	0.00	100.00	100.0	0.00	100	0.00	0.00
source (Energy & Peak Deficit):				Northern Region Electricity Board Annual Report 2004-2005				
Source: <a href="http://www.cea.nic.in">www.cea.nic.in</a>								

<sup>1</sup> Estimation based on the present capacity, deficit and project growth in energy demand for the region.



The Ministry of Non-conventional Energy Sources has targeted an increase of 10% of the total installed capacity in the year 2001, with 10,000 MW through renewable energy sources by the year 2012. The Northern region is expected to add about 2784<sup>2</sup> MW approximately. But, it is unlikely to achieve this target due to a number of constraints prevailing in the Northern region with regard to the terrain and regulation. Substantial nuclear capacity addition is not possible during the crediting period. Only two nuclear projects are under construction in the Northern region with a total capacity of 440 MW<sup>3</sup>, which are expected to commission during 2007.

As it appears above, the dependence will continue to be on fossil fuel based power generation sources such as coal and natural gas. This will increase the grid system carbon intensity from the present level.

To conclude, in the absence of the project activity, the power would be generated by the power plants in the Northern regional electricity grid (carbon intensive grid). This is in compliance with legal and regulatory requirements and therefore suitable to be considered as baseline for the project activity.

2. *The proposed project activity (installation of a power plant), fired with the same type of biomass but with a lower efficiency of electrical generation (e.g. an efficiency that is common practice in the relevant industry sector)*

In India, more or less all the sugar mills have their own cogeneration units, most of them operating with a low-pressure boiler configuration (21 kg/cm<sup>2</sup>) to cater their in-house steam and power requirements.

The boiler electrical energy efficiency (as defined under the methodology) for the reference plant configuration (i.e. baseline) will be one fourth (20.53 MWh/TJ) when compared to that of the project activity (50.22 MWh/TJ). Conventionally it is easier for sugar mills to opt for low efficiency cogeneration plants considering that they are less capital intensive. Cogeneration plants with outlet boiler pressure of 21-kg/cm<sup>2</sup> produce lesser power (as compared to MCM's 87 kg/cm<sup>2</sup>) and are less capital intensive. MCM had an option to install low or medium pressure boilers as against selected configuration of 87kg/cm<sup>2</sup>-outlet boiler pressure however they have implemented "modern and energy efficient technology", which was available in the country at the time the decision was taken for the implementation of the project activity.

By the time the project was conceived, the project activity was one of the first few in India and only the fourth in the state of Uttar Pradesh to implement the bagasse cogeneration with this pressure and temperature configuration. Hence it is clearly a unique project and not a business as usual scenario (BAU) as only four cogeneration plants with equivalent pressure and temperature configuration were implemented before the project i.e. Aug 2006.

---

<sup>2</sup> Total installed capacity in India in the year 2001 is about 100,000 MW. 10% of it is targeted for addition by the year 2012 through renewable energy sources. As per the Annual Report of 2001-2002 of the Ministry of Power, installed capacity in the Northern region is 27,843 MW in the year 2001 and 10% of the installed capacity amounts to 2,784 MW, which is expected to be added through renewable energy sources.

<sup>3</sup> Nuclear Power Corporation of India Ltd.: Rajasthan Atomic Power Station in Rajasthan. Units 5 & 6 of capacity 2 x 220 MWe are expected to be commissioning during 2007.





The total installed capacity in Uttar Pradesh as on 31st March 2005 (just prior to the project activity) was 73 MW from the biomass and cogeneration projects. The total power generation potential in the country is based on the bagasse as feed is estimated to be 5000 MW.<sup>4</sup> The estimated quantity in Uttar Pradesh is in excess of 1300 MW.

Power export to UPPCL grid by the project activity will replace the conventional power (contributed by a generation mix predominated by fossil fuel based power plants) by cleaner power and therefore enable GHG emission reductions.

From the above it is evident that, prior to the project activity, there was negligible contribution of energy through renewable energy sources in Uttar Pradesh. MCM's project activity, resulting in the export of green power to the UPPCL grid from 2006, is a unique and pioneering contribution to the state of Uttar Pradesh and India around the time of its implementation.

It is very likely that MCM would have opted to generate power necessary for the captive purposes by operating the lower efficiency boiler in the absence of the CDM project activity.

B2: The biomass (bagasse) is used to generate heat and power at the project site

In the absence of the proposed project activity (project plant) the plant would have generated the heat and power in the plant referred to as reference plant but with low electric efficiency. The proposed project does not increase the thermal firing capacity and the raw material input.

1. More than 96% of the bagasse would be used to generate steam and power in the low-pressure boiler and turbine system required for auxiliary, sugar plant and colony consumption
2. A very small portion (about 4 %) of excess bagasse would be stored in open silos at the project site where it would remain until it is used for start-up during the season and,
3. So far the unit has not diversified any bagasse outside the industrial facilities other than its own LP based power generation units.

Had the project activity not been implemented, biomass would have been mostly used for power generation in in-efficient manner. No bagasse would have been left to decay naturally or burn in an uncontrolled manner.

H2 - The proposed project activity (installation of a cogeneration power plant), fired with the same type of biomass but with a different efficiency of heat generation (e.g. an efficiency that is common practice in the relevant industry sector)

The generation of heat at MCM would have been generated in the lower pressure boilers using the same type of biomass (i.e. bagasse) in the absence of the project activity. Option H2 is the most likely baseline option. However, in the case of cogeneration plants, the consequences of the displacement of heat on GHG emissions need to be determined. Out of the 121 sugar mill units sanctioned /operating in the state of Uttar Pradesh, only four units other than MCM have such high configuration that the emissions are not increased. All four units have been developed under the CDM. It is then possible to admit that there would be no emission increases from the project activity.

---

<sup>4</sup> [http://www.mnes.nic.in/annualreport/2005\\_2006\\_English/CH2/3.htm](http://www.mnes.nic.in/annualreport/2005_2006_English/CH2/3.htm)



As the plant requires only 11.3 MW for its operations during the season, the project would have utilized mill generated bagasse as a fuel for the heat and electricity generation for on-site use only (i.e. by setting up a low pressure 21 ata boiler and generator set) and not exported any power to the grid. This would have resulted in 'excess' power (22.7 MW) is being generated by / in the Northern Indian grid.

**Option B:**

**The proposed project activity is not undertaken as a CDM project activity**

The promoters have gone on record with their reluctance to set up the bagasse cogeneration unit with such a high pressure boiler based power unit, primarily on account of the high capital cost and the inherent technical and operational risks involved. In fact, it was only when the CDM related revenue was highlighted that the investors agreed to invest the equity component required to fund the high-pressure configuration. Otherwise, the investors were of the opinion that the project was very risky and preferred to set up the project by installing a low-pressure boiler to cater the internal thermal and electrical energy needs of the plant as prevailing in the sector.

In addition, all (most) similar projects being set-up in the country (in the sugar segment) are being developed under the CDM. In view of the above, it may be concluded that at the point in time when the decision to proceed with the project was taken, the related CDM revenue was seriously considered and was a key factor in making the favorable decision (suitable documents will be provided to the DOE at the time of validation)

Thus the option to undertake this project as a non-CDM project was/is not a viable baseline scenario

*Sub-step 1b. Enforcement of applicable laws and regulations:*

Considering the business as usual practice in the sugar mill industry and the level of feasibility and conservativeness, the alternative project that must be chosen as the baseline scenario is the alternative that most likely and conservatively reflects how the electric power would have been generated if the proposed project activity had not been implemented.

This sugar mill would have complied with all outstanding legal and environmental regulations in India, as the alternative most sophisticated sugar mill currently does.

**Step 2: Investment analysis OR**

**Step 3: Barrier analysis**

MCM proceeds to establish project additionality by conducting the step 3. Barrier Analysis

**Sub-step 3a: Identify barriers that would prevent a wide spread implementation of the proposed project activity:**

***(A) Investment barriers:***



The factory has not historically been a grid generator and further operational barriers facing the project relate to the supply of power to the grid. The project participants would have to assemble all the technical and managerial means necessary to a successful operation of the plant. The sale of power to UPPCL presents a risk to the project. There is currently uncertainty surrounding the received price in the power purchase agreement. Whilst there is an MNES advised tariff this is not applied in Uttar Pradesh, the current price for electricity from bagasse cogenerations in UP is Rs 2.86/kWh. Along with the risk of final price for electricity there is also the risk of late payment by the UPPCL. These two factors provide significant risk that the project will face and the revenue from CERs would help reduce these risks.

Under the terms and condition of the power purchase agreement (PPA) granted to the project activity there remains an uncertainty in the tariff, the tariff may be reviewed post 2009 as there is no specified rate beyond the 2009-10 season. This provides considerable uncertainty to the project developer as to future rates in force. The actual tariff in the first year for the project activity will be Rs 2.86/kWh which is far below the earlier Ministry of Non-Conventional Energy Sources (MNES). The MNES advised a tariff of Rs 2.25 in 1994-95 escalated at a rate of 5%, which currently equates to a tariff of Rs 3.60/kWh.

The total project cost involved is 98.05 Crores. The banking and other funding institutions took on 50% of the project's total cost. It is costly to implement high-pressure configuration cogeneration projects as compared to conventional low pressure or medium- pressure cogeneration plants and that's the reason why most of the sugar plants in the state as well as in the country use low to medium pressure configurations.

MCM faced investment barriers and in particular a high upfront cost it was difficult to interest financial institutions and banks and to obtain financial closure for the project. As MCM had only been into the sugar production business with very little background in power sector economics, getting financial support from banks was a difficult proposition and having the investors provide bigger equity on proposing a HP steam-generating system is a daunting task.

In view of the above, the offer by Vitol S.A. to purchase the CERs at a price in the range of US\$ 8-11, together with its offer to organize for upfront funding in exchange for suitable collateral, should the company so desire played a very critical role in the decision making process for this project.

***(B) Technological barriers:***

The project activity has adopted a high-pressure co-generation technology, which was relatively new in Uttar Pradesh at the time the project activity was developed. The project activity uses a technology that still had a small market share and low penetration at the time the project was developed. The low penetration of this technology is due to the efficiency of existing equipments, to the availability of skilled manpower to operate the plant continuously *etc.* MCM was one of the first few companies in Uttar Pradesh to overcome the technology barrier by adopting 87kg/cm<sup>2</sup> pressure and STG of double extraction cum condensing type. The technological barrier becomes even more significant considering the untapped renewable energy potential in UP using bagasse as fuel. The total potential for power generation from the bagasse in UP is 1350 MW of which only 5% is being installed.

Furthermore, the cogeneration unit would be an integral part of Sugar Mill unit. With the implementation of the project, all standby units would have to forego, a valiant techno-economic decision, which requires streamline meticulous preventive checks. A one-time failure of the boiler and its auxiliaries would lead to



a production downturn in the mill. This would lead to huge financial losses and could adversely affect both fuel efficiency and PLF.

The following verse from the WADE report clearly states that the additional benefits are required for the sugar industry to adopt high-energy technology solutions.

*According to the world alliance for the decentralized energy, WADE (2004), as, until recently, the sale of surpluses was not a common practice in the sector, the industry developed units of low efficiency exclusively to guarantee self-sufficiency of energy and steam and to deal with the problem of the bagasse accumulation and elimination. Moreover, starting at the time the sugar mills' cogeneration facilities are replaced, or when a new cogeneration unit is created, the equipments have a lifetime of more than 20 years. The decision to purchase low efficiency equipments means that the plant will not take advantage of its potential surpluses of electricity. The choice of the equipments is decisive in order for the plant to make its electricity surplus potentially available. The incentives for more efficient technologies are an important factor in that aspect. Still, even in the case of new facilities, the interest rates don't always make it possible to adopt more efficient technological options.*

**(C) Other Barriers:**

**Managerial resource and organizational barrier:** MCM had to overcome the managerial resource barrier because of the lack of trained manpower to operate the cogeneration plant. Considering that the plant is situated in a rural area and that MCM has long been involved in the business of sugar production and rural economics, it had to develop skills in dealing with the economics of electricity generation and distribution and in dealing with power sector economics and related.

**Institutional Barrier:** MCM's cash flows from the selling of power are entirely dependent on the economic situation of the state electricity boards (UPPCL). The MCM project activity has signed a power purchase agreement (PPA) with UPPCL against the sale of electricity to the grid. It is acknowledged that the condition of electricity boards in India is not very healthy and it is likely that, there would be problems with MCM's cash flows. In Uttar Pradesh, the total outstanding amount still due to central power sector units as on 30<sup>th</sup> June 2006 were 1791.5 crores. MCM had to take this risk and face this institutional barrier on which they have limited or no control and therefore CDM funds are critical to MCM.

It is also to be noted that as per the electricity act 2003 the share of renewable should be 10% of the total installed capacity, where as Uttar Pradesh has reduced to 7.5 % which may lead for the project activity to reduce its generation PLF as it happened in nearby states. Under that condition the project could only survive with the additional CDM benefits.

UPPCL has also undergone an experience as one of the high technical and commercial loss making Power Corporation in the country.

**Grid Synchronization:**

As per the wheeling agreement with UPPCL, this one cannot be held responsible for any damage, whatsoever, that may be caused to the generating sets or any other equipment installed in CPP on account of parallel operation with the Northern regional grid, and UPPCL shall not be responsible to pay any



compensation for any such damages. The protection system will have to be provided at the company's expense to ensure no damages are done due to the paralleling of the CPP. Relays at the board's substation will be tested at intervals of six months and results will be furnished to the company. The repair/ replacement/ maintenance of such protection equipments shall be at the company's expense. It is also to be kept in mind that more than two times the northern region grid failed due to imbalance.

**Sub-step (3b). Show that the identified barriers would not prevent a wide spread implementation of at least one of the alternatives (except the project activity already considered in step 3a):**

Since the barriers mentioned above are directly related to venturing into the business of export of power to a grid (sale of electricity) there are no impediments for sugar manufacturing plants and also MCM to implement any of these alternatives.

Barriers discussed above are strong enough to hinder the sector's growth as it appears in the data on the 'Common Practice Analysis' of bagasse-based cogeneration (discussed below) and therefore the project activity is additional, as it has overcome the above barriers by taking up the risk of implementing this power project.

Furthermore, these barriers do not exist for the alternatives/ options discussed above and thus do not prevent the widespread implementation of these alternatives.

**Step 4: Common Practice Analysis**

**Sub-step 4a: Analyse other activities similar to the proposed project activity:**

Historically, the sector has always exploited its biomass in an inefficient manner by using low-pressure boilers. Although they consume almost all the biomass for energy generation, this energy is used for in-house consumption purposes and it is done in such a manner that no surplus electricity is available for sale, and very few (if any) companies have ventured in the electricity market, till very recently.

From Steps 1, 2 and 3 it can be concluded that the option/ alternative (combination of power generation, steam generation and biomass use), does not have hurdles or barriers, which prevent their implementation. However, the project activity faces managerial, institutional and investment barriers, which could prevent MCM from implementing it as already elaborated in the 'Barrier Analysis'.

The common practice scenario as tabulated below in Table 2.1 substantiates that the project activity without CDM benefits is not a preferred proposition for the sugar-manufacturing units placed in the Uttar Pradesh State socio-economic environment. The low efficiency and turbine configuration (which meets the plant's energy requirements with no surplus power generation) is the most common practice adopted by the sugar- manufacturing units across the country. The Indian sugar manufacturers have been utilizing their bagasse in an inefficient manner by using low-pressure boilers (with low electrical and thermal energy efficiency) to generate steam and electricity only for in-house consumption.

For a similar project sector, socio-economic environment, geographic conditions and technological circumstances, the project activity uses an efficient technology, which is not a common practice.



Table 2.1: Common Practice Analysis for MCM project activity

<i>Total number of Sugar Mills in Uttar Pradesh (as on Dec 2004)</i>	120
<i>Co-generation unit to meet plant energy requirement with no surplus power</i>	93
<i>Co-generation unit to meet plant energy requirement with some surplus power</i>	7
<i>Co-generation unit to meet plant energy requirement with some surplus power generation, all with CDM revenue / being developed under the CDM.</i>	4
<i>Closed Sugar mills</i>	17
Reference :Indian Sugar Mill Association (ISMA)	

Before the project activity was implemented there were only four sugar mills in the state of Uttar Pradesh (UP) out of 121 sugar mills, operating with a grid connected cogeneration unit of high-pressure configuration of 87 kg/cm<sup>2</sup> (an equivalent configuration as of the proposed project) and above. This shows a very low penetration of technology (3.3 % in UP) and justifies that the project activity is additional.

The majority of projects implemented / under implementation are targeting registration under the Clean Development Mechanism in order to generate additional revenues that are so essential to make the projects viable and thus possible.

***Sub-step 4b: Discuss any similar options that are occurring***

Most of the similar projects have been implemented recently and most, if not all, of them are being developed under the Clean Development Mechanism.

**Step 5: Impact of CDM registration**

The registration of this CDM project activity will contribute in overcoming all the barriers described in this tool: technological, institutional, economic, investment, and other barriers will all be significantly mitigated on the account of the additional revenue generation from the sale of carbon credits. This would bring more solidity to the investment itself, thus fostering and supporting the project owner's decision to break through on their business model. The project activity is already engaged in negotiations to sell their expected CERs.

In addition, the CDM project registration would influence other similar projects to be set up and encourage the use of CERs as an additional revenue stream that is reliable enough to be seriously considered in the project's returns computation.

It is ascertained that the project activity would not have occurred in the absence of the CDM simply because no sufficient financial, policy, or other incentives exist locally to foster its development in India. Without the proposed carbon financing for the project, the MCM would not have taken the investment risks in order to implement the project activity. Further CDM funds will provide additional coverage to the risk attached to the failure of the project activity, the shutting down of the plant and the loss of production. In such an event the BAU baseline option is continued with release of carbon dioxide emissions.



Furthermore, with the CDM project activity registration, many more sugar manufacturing industries in India would take up similar initiatives under the CDM, overcoming the barriers to project activity implementations, and resulting in higher quantum of anthropogenic greenhouse gas emissions reductions.

## B.6. Emission reductions:

### B.6.1. Explanation of methodological choices:

>>

The project activity mainly reduces CO<sub>2</sub> emissions through the substitution of power and heat generation with fossil fuels by energy generation with biomass. The emission reductions  $ER_y$  linked to the project activity during a given year  $y$  is given by:

$$ER_y = ER_{heat,y} + ER_{electricity,y} + BE_{biomass,y} - PE_y - L_y$$

Where

$ER_{heat,y}$  are the emission reductions due to displacement of heat during the year  $y$  in tons of CO<sub>2</sub>,  
 $ER_{electricity,y}$  are the emission reductions through substitution of electricity generation with fossil fuels  
 $BE_{biomass,y}$  are the baseline emissions due to natural decay or burning of anthropogenic sources of biomass during the year  $y$  in tons of CO<sub>2</sub> equivalents,  
 $PE_y$  are the project emissions  
 $L_y$  are emissions due to leakage

#### Emission reductions due to displacement of heat ( $ER_{heat,y}$ )

MCM has not claimed for emission reductions due to heat generation in the project activity but is required to demonstrate that emissions do not arise from combustion of more bagasse.

The thermal efficiency in the project plant is larger than the thermal efficiency of the reference plant. In the project activity additional biomass is being fired to generate higher quantum of heat generation for both process steam and for power generation. Since the increased level of heat generation in the MCM project activity is attributed to additional bagasse being fired in the project activity and therefore the additional heat generation can be assumed not to involve additional emissions and therefore  $ER_{heat,y} = 0$ .

#### Emission reductions due to displacement of electricity ( $ER_{electricity,y}$ )

Emission reductions due to the displacement of electricity are relevant for all scenarios as per ACM 0006 and are calculated by multiplying the net quantity of increased electricity generated with biomass as a result of the project activity ( $EG_y$ ) with the CO<sub>2</sub> baseline emission factor for the electricity displaced due to the project ( $EF_{electricity,y}$ ), as follows:

$$ER_{electricity,y} = EG_y * EF_{electricity,y}$$

Where:



$ER_{electricity,y}$  are the emission reductions due to displacement of electricity during the year  $y$  in tons of CO<sub>2</sub>,

$EG_y$  is the net quantity of increased electricity generation as a result of the project activity (incremental to baseline generation) during the year  $y$  in MWh,

$EF_{electricity,y}$  is the CO<sub>2</sub> emission factor for the electricity displaced due to the project activity during the year  $y$  in tons CO<sub>2</sub>/MWh.

Since the power generation capacity of the biomass cogeneration plant is more than 15MW,  $EF_{grid,y}$  (since  $EF_{electricity,y} = EF_{grid,y}$ ) is calculated as a combined margin (CM), following the guidance in the section “baselines” in the “Consolidated baseline methodology for grid-connected electricity generation from renewable sources” (ACM 0002)

$$EG_y = EG_{project\ plant,y} - \varepsilon_{el,reference\ plant} * \sum BF_{i,y} * NCV_i$$

Where:

$EG_{project\ plant,y}$  is the net quantity of electricity generated in the project plant during the year  $y$  in MWh,

$\varepsilon_{el,reference\ plant}$  is the average net energy efficiency of electricity generation in the “reference plant”, expressed in MWh<sub>el</sub>/TJ<sub>biomass</sub>

$BF_{i,y}$  is the quantity of biomass type  $i$  used as fuel in the project plant during the year  $y$  in a volume or mass unit, and

$NCV_i$  is the net calorific value of the biomass type  $i$  in terajoules (TJ) per mass or volume of biomass

### Baseline emissions due to natural decay or uncontrolled burning of anthropogenic sources of biomass

In the case of scenario 4, in the absence of the project activity, the biomass would still be used to generate power and would not be left to natural decay or uncontrolled burning.

Baseline emissions due to the natural decay or uncontrolled burning of anthropogenic sources of biomass are assumed to be zero  $BE_{biomass,y} = 0$ .

### Project Emissions (PE<sub>y</sub>)

Project emissions include CO<sub>2</sub> emissions from the transportation of biomass to the project site ( $PET_y$ ) and CO<sub>2</sub> emissions from the on-site consumption of fossil fuels due to the project activity ( $PEFF_y$ ) and, where this emission source is included in the project boundary and relevant, CH<sub>4</sub> emissions from the combustion of biomass ( $PE_{Biomass, CH_4, y}$ ):

$$PE_y = PET_y + PEFF_{co2,y} + GWP_{CH_4} * PE_{Biomass, CH_4, y}$$

Where:

$PET_y$  are the CO<sub>2</sub> emissions during the year  $y$  due to transport of the biomass to the project plant in tons of CO<sub>2</sub>,

$PEFF_{CO_2,y}$  are the CO<sub>2</sub> emissions during the year  $y$  due to fossil fuels co-fired by the generation facility in tons of CO<sub>2</sub>,





$GWP_{CH_4}$  is the Global Warming Potential for methane valid for the relevant commitment period,  
 $PE_{Biomass, CH_4, y}$  are the CH<sub>4</sub> emissions from the combustion of biomass during the year  $y$ .

Project emissions from Biomass transportation to the power plant ( $PET_y$ )

There is no fossil fuel combustion for transportation of bagasse. Bagasse is mill generated bagasse and therefore  $PET_y = 0$

Project emissions from combustion of fossil fuel in the power plant ( $PEFF_{CO_2, y}$ )

There is no fossil fuel combustion associated with the project activity. Hence there is no project emissions associated to fossil fuel combustion due to the MCM project activity implementation ( $PEFF_{CO_2, y} = 0$ ). Therefore project emissions due to the fossil fuel combustion have not been considered.

**Leakage ( $L_y$ )**

The main potential source of leakage for this project activity is an increase in emissions from fossil fuel combustion due to diversion of biomass from other users to the project as a result of the project activity. With the baseline scenario wherein the use of biomass for energy generation is considered, the diversion of biomass to the project activity is already considered in the calculation of baseline reductions. Hence, no leakages are considered for the project activity.

Since the MCM sugar plant is a Greenfield power project, the bagasse generated at the sugar plant was not available for use to the other users. Therefore there is no diversion of biomass resulting to an increase in emissions from fossil fuel combustion at other sources with respect to the quantity of bagasse generated in MCM sugar plant.

**Emission Reductions**

The total emission reductions due to the project activity are presented in the following sections.

**B.6.2. Data and parameters that are available at validation:**

*(Copy this table for each data and parameter)*

<b>Data / Parameter:</b>	<b>EF<sub>y</sub></b>
Data unit:	tCO <sub>2</sub> /GWh
Description:	CO <sub>2</sub> emission factor of the grid
Source of data used:	Calculated as weighted sum of OM and BM emission factors
Value applied:	914.8
Justification of the choice of data or description of measurement methods and procedures actually applied :	Information available from CEA annual reports
Any comment:	-

<b>Data / Parameter:</b>	<b>EF<sub>OM, y</sub></b>
--------------------------	---------------------------



Data unit:	tCO <sub>2</sub> /GWh
Description:	CO <sub>2</sub> operating emission factor of the grid
Source of data used:	Calculated as indicated in the relevant OM baseline method of ACM0002
Value applied:	1137.9
Justification of the choice of data or description of measurement methods and procedures actually applied :	Information available from CEA annual reports
Any comment:	--

<b>Data / Parameter:</b>	<b>EF<sub>BM,y</sub></b>
Data unit:	tCO <sub>2</sub> /GWh
Description:	CO <sub>2</sub> build emission factor of the grid
Source of data used:	Calculated as indicated in the relevant BM baseline method of ACM0002
Value applied:	691.77
Justification of the choice of data or description of measurement methods and procedures actually applied :	Information available from CEA annual reports
Any comment:	-

### B.6.3 Ex-ante calculation of emission reductions:

>>

The project activity mainly reduces CO<sub>2</sub> emissions through the substitution of power and heat generation with fossil fuels by energy generation with biomass. The emission reductions  $ER_y$  linked to the project activity during a given year  $y$  is given by:

$$ER_y = ER_{heat,y} + ER_{electricity,y} + BE_{biomass,y} - PE_y - L_y$$

Where

$ER_{heat,y}$  are the emission reductions due to displacement of heat during the year  $y$  in tons of CO<sub>2</sub>,  
 $ER_{electricity,y}$  are the emission reductions through substitution of electricity generation with fossil fuels  
 $BE_{biomass,y}$  are the baseline emissions due to natural decay or burning of anthropogenic sources of biomass during the year  $y$  in tons of CO<sub>2</sub> equivalents,  
 $PE_y$  are the project emissions  
 $L_y$  are emissions due to leakage

**Emission reductions due to displacement of heat ( $ER_{heat,y}$ ):  $ER_{heat,y} = 0$ .**

**Emission reductions due to displacement of electricity ( $ER_{electricity,y}$ )**

$$ER_{electricity,y} = EG_y * EF_{electricity,y}$$

$$EG_y = 111 \text{ GWh per year}$$

$$EF_{electricity,y} = 914.88 \text{ tCO}_2/\text{GWh}$$

The plant operates around 165 days during the crushing season with the balance of about 65 days off-season days. The cogeneration plant will operate during the off-season with the saved bagasse during the seasonal operation of the MCM sugar plant.

**Baseline emissions due to natural decay or uncontrolled burning of anthropogenic sources of biomass:**  $BE_{biomass,y} = 0$ .

**Project Emissions ( $PE_y$ ):**  $PE_y = 0$  (Refer to section B.6.1)

**Leakage ( $L_y$ )**  $L_y = 0$  (Refer to section B.6.1)

<b>B.6.4 Summary of the ex-ante estimation of emission reductions:</b>
------------------------------------------------------------------------

&gt;&gt;

The emission reduction  $ER_y$  by the project activity during a given year  $y$  is given by:

$$ER_y = ER_{heat,y} + ER_{electricity,y} + BE_{biomass,y} - PE_y - L_y$$

<i>Year</i>	<i>Project activity emissions (tCOe/yr)</i>	<i>Baseline emissions tCO2/yr</i>	<i>Emissions Reductions from the project activity tCO2/yr</i>
August 2006	0	42,497	42,497
2007	0	1,01,993	1,01,993
2008	0	1,01,993	1,01,993
2009	0	1,01,993	1,01,993
2010	0	1,01,993	1,01,993
2011	0	1,01,993	1,01,993
2012	0	1,01,993	1,01,993
Jan 2013 – July 2013	0	59,496	59,496

<b>B.7 Application of the monitoring methodology and description of the monitoring plan:</b>
----------------------------------------------------------------------------------------------

<b>B.7.1 Data and parameters monitored:</b>
---------------------------------------------

(Copy this table for each data and parameter)

<b>Data / Parameter:</b>	<b>BF<sub>y</sub></b>
Data unit:	Tons
Description:	Quantity of bagasse combusted in the project plant during the year $y$



Source of data to be used:	Onsite measurement
Value of data applied for the purpose of calculating expected emission reductions in section B.5	Total annual bagasse sent for combustion
Description of measurement methods and procedures to be applied:	The total bagasse generated at the sugar plant will be measured continuously. The data will be recorded in paper and will be archived for crediting + 2 years.
QA/QC procedures to be applied:	Yes. Direct measurement of the data at the plant site will be cross-verified against the production. Manager Incharge would be responsible for calibration of the meters as per national standards.
Any comment:	-

<b>Data / Parameter:</b>	<b>NCVi</b>
Data unit:	Kcal/kg
Description:	Net calorific value of bagasse in the project plant in year
Source of data to be used:	Plant records
Value of data applied for the purpose of calculating expected emission reductions in section B.5	Net calorific value of bagasse in the project plant in year
Description of measurement methods and procedures to be applied:	The net calorific value of the total bagasse generated at the sugar plant will be conducted inhouse. The data will be recorded in paper and will be archived for crediting + 2 years.
QA/QC procedures to be applied:	Yes. Check consistency of measurements and local/national data with default values by the IPCC.
Any comment:	-

<b>Data / Parameter:</b>	<b>EG project plant</b>
Data unit:	MWh
Description:	Total quantity of electricity generated in the project plant in the year y
Source of data to be used:	Plant records
Value of data applied for the purpose of calculating expected emission reductions in section B.5	Total quantity of electricity generated in the project plant in the year y
Description of	The project activity will have a DCS system to measure the data accurately. The



measurement methods and procedures to be applied:	digital meters are used to ensure high accuracy level.
QA/QC procedures to be applied:	Yes. Direct measurement of the data at the plant site will be cross-verified against the receipts of export. Manager Incharge would be responsible for calibration of the readings.
Any comment:	-

<b>Data / Parameter:</b>	<b>EGaux</b>
Data unit:	MWh
Description:	Electricity for auxiliary consumption in the project plant in the year y
Source of data to be used:	Plant records
Value of data applied for the purpose of calculating expected emission reductions in section B.5	Electricity for auxiliary consumption
Description of measurement methods and procedures to be applied:	The project activity will have a DCS system to measure the data accurately. The digital meters are used to ensure high accuracy level.
QA/QC procedures to be applied:	Yes. Direct measurement of the data at the plant site will be cross verified against the plant records. Manager Incharge would be responsible for calibration of the readings.
Any comment:	-

<b>Data / Parameter:</b>	<b>EGy</b>
Data unit:	MWh
Description:	Net quantity of electricity generated in the project plant in the year y
Source of data to be used:	Plant records
Value of data applied for the purpose of calculating expected emission reductions in section B.5	Net quantity of electricity generated
Description of measurement methods and procedures to be applied:	The project activity will have a DCS system to measure the data accurately. The digital meters are used to ensure high accuracy level.
QA/QC procedures to be applied:	Yes. Direct measurement of the data at the plant site will be cross verified against the plant records. Manager Incharge would be responsible for calibration



	of the readings.
Any comment:	

<b>B.7.2 Description of the monitoring plan:</b>
--------------------------------------------------

>>

The methodology requires the project-monitoring plan to consist of metering the electricity generated by the project activity, total electricity generated by the unit at site, quantity of bagasse fired in project activity, calorific value of bagasse and net quantity of heat generated by project plant.

Energy meters would be used for monitoring the energy generated. The energy meters shall be maintained in accordance with electricity standards in India. Each meter would be inspected and sealed and shall not be interfered with by anyone.

Total quantity of bagasse fired in the project plant would be measured on the weighbridge. The weighbridge would be tested for accuracy every year. If during yearly test check, Weigh Bridge is found to be beyond permissible limits of error it would be calibrated immediately

The MCM project activity has employed the monitoring and control equipment that measure, record, report, monitor and control various key parameters. These monitoring and controls are a part of the DCS of the entire plant. All monitoring and control functions have been as per the internally accepted standards and norms of MCM, which were based on national and internationally industry standards.

***Project Parameters affecting Emission Reduction***

**Monitoring Approach**

The general monitoring principles are based on:

- Frequency
- Reliability
- Registration and reporting
- Bagasse Requirement and Utilization

As the number of units exported to the grid determines the emission reductions from the project, it becomes important for the project to monitor the net export to the grid on real time basis.

***Frequency of monitoring***

The project developer has installed all metering and check metering facilities within the plant premises as well as in the grid substation where exported power is connected to the grid. The measurement will be recorded and monitored on a continuous basis by both UPPCL and the project developer through DCS.

***Reliability***

The amount of emission reduction units is proportional to the net energy generation from the project. Thus the final KWh meter reading is the final value from project side. All measurement devices are of microprocessor based with best accuracy procured from reputed manufacturers. Since the reliability of the monitoring system is governed by the accuracy of the measurement system and the quality of the



equipment to produce the result all power measuring instruments is calibrated once a year for ensuring reliability of the system. All instruments carry tag plates, which indicate the date of calibration and the date of next calibration. Therefore the system ensures the final generation is highly reliable.

#### *Registration and reporting*

Registration of date is on-line in the control cabin through a microprocessor. However, hourly data logging will be there in addition to software memory. Daily, weekly and monthly reports are prepared stating the generation. In addition to the records maintained by the MCM, UPPCL also monitors the power exported to the grid and certify the same.

The other major factors, which need to be ensured and monitored, are: the use of bagasse fuel for power generation, power for the sugar plant, power for auxiliary purpose and the parameters that would ensure smooth and regular operation of the cogeneration. No other project specific indicators are identified that affect the emission reductions claims.

#### *Bagasse Requirement and Utilization*

Availability of Bagasse: The major fuel used by the cogeneration power plant is bagasse, generated by the sugar mill of MCM. The bagasse after sugar processing will be supplied to cogeneration plant. Hence, production of electricity is mainly depending on the bagasse received from this sugar mill. The receipt of bagasse to cogeneration plant mainly depends on the total cane crushed by the sugar mill

Quantity of the Bagasse fuel used in the boiler: The total amount of bagasse received from sugar unit will be based on the total sugar cane crushing and bagasse generated. The plant operates around 165days during the crushing season with the balance of about 65 off-season days. The cogeneration plant will operate during the off-season with the saved bagasse during the seasonal operation of the sugar plant.

The fuel entered into the plant premises will be first dumped in the fuel storage area from where it will be taken to the fuel processing machinery with the help of belt conveyors. The fuel processing machinery will cut the bagasse fuel into the required size and the processed bagasse fuel will be taken to boiler bunkers with the help of belt conveyors from where the fuel finally enters the boiler.

The belt conveyors which feed the bagasse fuel from processing machinery to boiler bunkers, consists of a metal detector, tramp iron detector, magnetic separator and online weighing system. Metal detector, tramp iron separator etc. will prevent any metal particles entering into the boiler and ensure that only fuel is conveyed to the boiler. An online weighing system provided to the belt conveyors measures, records and transmits the actual quantity of the fuel entering into the boiler for online monitoring in the DCS. The weighing system will be calibrated regularly to ensure the accuracy of the measurement. The data will be recorded for further verification.

Since it is mandatory for sugar industries to submit yearly performance record, which also includes above parameters, to the government, these figures are to be crosschecked from this record. In case of any fossil fuel would be purchased this will also become evident from the audit report.

The main type of fuel proposed for the power generation is only bagasse. The properties of the bagasse fuels like ultimate analysis, calorific value, ash composition etc. are already established and will be consistent in the region. However, it is proposed to monitor various properties of bagasse fuels by taking



samples at random from the fuel lots from the processed fuel so that in case of any drastic change in the properties, corrective actions can be taken. The measurement of fuel properties like ultimate analysis, calorific value etc. will be done at reputed laboratories as per international practices and date or documents will be kept open for verifiers. The data will also be computerized and monitored through management information system of the DCS.

B.8 Date of completion of the application of the baseline study and monitoring methodology and the name of the responsible person(s)/entity (ies)
---------------------------------------------------------------------------------------------------------------------------------------------------

>>

The date of completion of the baseline study: 30/11/2006

Mankapur Chini Mills and their consultant





**SECTION C. Duration of the project activity / crediting period**

**C.1 Duration of the project activity:**

**C.1.1. Starting date of the project activity:**

>>  
20/08/2005

**C.1.2. Expected operational lifetime of the project activity:**

>>  
30y-0m

**C.2 Choice of the crediting period and related information:**

**C.2.1. Renewable crediting period**

**C.2.1.1. Starting date of the first crediting period:**

>>  
15/08/2006 or Date on which the registration occurs

**C.2.1.2. Length of the first crediting period:**

>>  
7y-0m

**C.2.2. Fixed crediting period:**

**C.2.2.1. Starting date:**

>>  
Not applicable

**C.2.2.2. Length:**

>>  
Not applicable

**SECTION D. Environmental impacts**

&gt;&gt;

**D.1. Documentation on the analysis of the environmental impacts, including transboundary impacts:**

&gt;&gt;

According to Indian regulation, the implementations of biomass plants do not require an Environmental Impact Assessment (EIA). The Ministry of Environment and Forests (MoEF), Government of India notification dated June 13, 2002 regarding the requirement of EIA studies as per the Environment Protection Rule, 1986 (MoEF, 2002) states that any project developer in India needs to file an application to the MoEF (including a public hearing and an EIA) in case the proposed industry or project is listed in a predefined list.

Though the project does not require conducting EIA as per MOEF rules, by considering the high level of investment involved in the project, the project promoter has conducted EIA study.

**D.2. If environmental impacts are considered significant by the project participants or the host Party, please provide conclusions and all references to support documentation of an environmental impact assessment undertaken in accordance with the procedures as required by the host Party:**

&gt;&gt;

Environmental Protection and the control of solid, liquid and gaseous effluents or emissions are key elements in the design of all steam and power generating systems. The emissions from combustion systems are tightly regulated by State and Central Governments and there are specific rules and requirements that are constantly changing. The measures taken to reduce the environmental impacts of the cogeneration power plant project are in following areas:

**Air:**

The elements polluting the air that are discharged from the power plant are- dust particulate from fly ash in flue gas, nitrogen oxide and sulphur di oxide. The Pollution Control Regulation limits the particulate matter emission from bagasse fired steam generators as 150 mg/Ncum. MCM has taken this step of installation of Electrostatic precipitator (ESP) for reduction of particulate emission to 50 Mg/Ncum to save the environment from dust emission. There is no sulphur in bagasse and hence the criterion for fixing stack height based on sulphur di oxide emissions is not applicable here. The temperatures encountered in the steam generator while burning high moisture bagasse are low enough not to produce nitrogen-oxides. The fly ash collected from the ESP hoppers; air heater hoppers and furnace bottom hoppers can be used for landfill. The high potash content in the bagasse makes the ash good manure. It is mixed with filter mud obtained from sugar plant, which has good land nutrient value, and this mixture is sold to the farmers to be used as manure in cane fields.

**Water:**

The acid and alkali effluents generated during the regeneration process of the ion exchangers would be drained into an epoxy lined underground neutralizing pit. Generally these effluents are self-neutralizing. However, provisions are made so that the effluents will be neutralized by addition of either acid or alkali to achieve the required pH of about 7.0. Wastewater would be treated before discharge i.e. they would be subjected to filtration and clarification. The oily water will be treated separately to remove oil/ grease



before discharge into effluent ponds. Clarification is used to settle out large suspended particles and condition smaller colloidal particles to make them settle. The treated water would be used for greenery development and cane farms. A close circuit cooling water system with cooling towers would eliminate letting out of high temperature water into the canals and prevents thermal pollution.

#### Noise:

The rotating equipment in the power plant will be designed to operate with a total noise level not exceeding 85 to 90db (A) as per the requirement of the Occupational Safety and Health Administration (OSHA) Standards. The rotating equipments are provided with silencers whenever required to meet the noise pollution.

As all the necessary pollution control measures to maintain the emission levels of dust and SO<sub>2</sub> are taken and other effluents will be treated in the effluent treatment plant, there will be no adverse impact on either the air or water quality in and around the power plant site.

The impacts identified on various components of environment are studied during two different phases - construction phase and operational phase. The important aspects of the report are summarized as follows:

#### **During Construction Phase**

The proposed installation of the plant is in remote area. The installation of the power plant would have positive a effect on landscaping. Project proponents will improve the aesthetics of the surroundings. The land section was under agriculture and therefore, construction would not require any tree to be uprooted. There are no endangered species to be uprooted for the project.

At initial stages of construction itself, a bore well shall be constructed for meeting the requirements of construction and also drinking water, for which necessary treatment facilities shall be installed. There would be short-term negative impacts on various components of socio-economic environment due to the increase of population comprising of the workforce. However, by providing adequate housing, water, and power and sanitation facilities for the construction workforce, these impacts shall be contained within the site. Contractors shall also arrange adequate cooking fuel. Thus, this short-term negative impact may be contained within the site and minimized. Further, there is a small village close to the construction site. Bulk of the requirement of unskilled labor shall be met from this village, thereby significantly reducing the short-term negative impact.

#### **During Operational Phase**

The thermal energy emitted in the environment by power generating stations has long-term negative impacts. However, the proposed installation is insignificantly small to bring about climatic changes. Furthermore, the plant is based on a renewal form of energy – biomass. The air pollution from the burning of such fuel is less harmful as they contain lesser quantity of sulphur (~0.6%) as fossil fuels. Particulate emissions would be prevented by ESP (control equipment) and thus minor negative long-term impact on air environment is envisaged. An electrostatic precipitator installed with the boiler would capture almost the entire quantity of ash thereby practically eliminating all particulate related problems.

Requirements of water are proposed to be meet with the bore well available at the site. The yield of the ground water and potential for sustained availability has been established. No surface water bodies are available in the vicinity & therefore, would not be exploited for operation of the plant, thus surface water would not receive any impact. Further, the blow down water & effluents used for green belt



development, ash quenching and sprinkling over heaps of fuel would percolate to the ground water and would cause recharge of the ground water body to a sizable extent. Thus, long-term negative impact of moderate magnitude is anticipated on the ground water during operational phase of the plant.

The ecological environment shall have no impact due to operation of the plant.

#### **GHG emission reduction**

There would be contribution towards global environmental improvement due to positive impact of the plant on reduction of green house gas emission. Power generation from biomass is fundamentally carbon dioxide emission free due to the recycling of the carbon through the plant route. Thus, the entire quantity of power can be considered to substitute fossil fuel generated power. The project proponent would explore possibility of getting emission credits under CDM of Kyoto Protocol.

#### **Social impact**

The socio-economic environment shall be impacted due to the minor increase in population. This will be reduced as the plant enters the operational phase after the construction phase. A very low negative long-term impact is envisaged on demography, sanitation, health and education aspects. Moderate long-term negative impacts due to an increase in traffic are also anticipated for the operational phase, the effect of which would be reduced by the implementation and maintenance of roads.

Due to the requirement of skilled workmen and labor in the power plant, there would be an increase in earning capacity of the local population. Similarly, the increased production in the industrial area would enhance trade and commerce related activities. There would be further income generation through primary and secondary employment opportunities in the plant and in the operation of fuel logistics.

No negative environmental impacts will occur as a result of the project activity. The positive environmental impacts arising from the project activity are: a reduction in carbon dioxide emissions from the replacement of fossil fuels that would be generated under the baseline scenario.

**SECTION E. Stakeholders' comments**

&gt;&gt;

**E.1. Brief description how comments by local stakeholders have been invited and compiled:**

&gt;&gt;

The stakeholders identified for the present project are as under:

- Village Panchayat
- Uttar Pradesh Power Corporation Ltd. (UPSEB)
- Uttar Pradesh Pollution Control Board (UPPCL)
- Project consultants
- Equipment Suppliers

Name of the Stakeholder	Description	Status
Village Panchayat	Accords permission for setting up of the project under the jurisdiction of the village. The village Panchayat /local elected body of representatives administering the local area are a true representative of the local population in a democracy like India. Hence the public comments received from the village Panchayat / elected body of representatives administering the local area give a proper reflection of the opinions of the local people. The village representative in the Village was also approached and also expressed their consent to operate.	The project proponent approached the village panchayat, the local body has appreciated the project and there are no comments received.
Uttar Pradesh Power Corporation Limited (UPPCL)	UPPCL, a regulatory body that purchases power from the MCM. Accords clearances for setting up of industries in the state. The project has completed the necessary agreement from UPPCL.	Achieved
Uttar Pradesh Pollution Control Board (UPPCB)	UPPCB, a regulatory body to monitor environmental impacts and environmental management of industries. Accords clearances for setting up of industries in the state after ensuring adherence to the statutory regulations. Also gives consent to start the operation of the project if satisfied with the environmental management and pollution control measures. The project has acquired the necessary clearances from UPPCB.	Achieved



Project Consultants (Consultancy)	Project consultants were involved in the project activity to take care of various pre-contract and post-contract project activities like preparation of Detailed Project Report (DPR), preparation of basic and detailed engineering documents, preparation of tender documents, selection of vendors / suppliers, and supervision of project implementation.	Completed
Equipment Suppliers	Supplied the equipment as per the specifications finalized for the project and are responsible for successful erection & commissioning of the same at the site.	Completed

**E.2. Summary of the comments received:**

&gt;&gt;

Name of the Stakeholder	Clearances and Summary of comments
Village Panchayat	Achieved. No comments received.
UPPCL	Achieved. No comments received.
UPPCB	Achieved. No comments received.
Project Consultants	No comments received.
Equipment Suppliers	No comments received.

**E.3. Report on how due account was taken of any comments received:**

&gt;&gt;

No comments have been received.

**Annex 1****CONTACT INFORMATION ON PARTICIPANTS IN THE PROJECT ACTIVITY**

Organization:	Mankapur Chini Mills (MCM)
Street/P.O.Box:	AJC Bose Road
Building:	FMC Fortuna II nd floor, 234/3A
City:	Kolkata
State/Region:	West Bengal
Postfix/ZIP:	700 020
Country:	India
Telephone:	+91-33- 2287 4749
FAX:	+91-33- 2240 3083
E-Mail:	<a href="mailto:kshah@chinni.com">kshah@chinni.com</a>
URL:	<a href="http://www.chinni.com">www.chinni.com</a>
Represented by:	
Title:	Director and Chief Financial Officer
Salutation:	Mr.
Last Name:	Shah
Middle Name:	
First Name:	Kishore
Department:	
Mobile:	
Direct FAX:	
Direct tel:	
Personal E-Mail:	

**Annex 2****INFORMATION REGARDING PUBLIC FUNDING**

There is no funding from Annex- I parties

**Annex 3****BASELINE INFORMATION**

The Indian power grid system is divided into five regions namely Northern, Southern, Eastern, Western and North Eastern regions. These regions have independent load dispatch centres. The Northern region mainly consists of Delhi, Uttar Pradesh, Rajasthan, Uttaranchal, Haryana, Himachal Pradesh, Punjab and Jammu Kashmir states. Each state has its own State Electricity Boards / Corporations to manage its power generating plants.

In Uttar Pradesh state, Uttar Pradesh Power Corporation Limited (UPPCL) manages the power transmission and distribution. Uttar Pradesh Rajya Vidyut Utpadan Nigam Limited (UPRVUNL) manages all the thermal power generation plants in the state and the hydro power plants are managed by Uttar Pradesh Jal Vidyut Nigam Limited (UPJVNL). National Thermal Power Corporation (NTPC) and National Power Corporation (NPC) manage the central government owned power generation plants.

The relevant grid for the determination of the combined margin is the Northern region grid. This is because although electricity generation and distribution remains largely in the hands of the Uttar Pradesh Power Corporation Limited, the regional grid is becoming more integrated. Moreover, central sector generation from the entire Northern region is transmitted to UP.

The actual generation data of the northern grid for the recent five years are analysed.

Fuel	GWh									
	2005	%	2004	%	2003	%	2002	%	2001	%
Hydro & Nuclear	43577	25.82	44662	26.859	38863	24.98	37239	24.6	35741	24.77
Coal, NG, Diesel	125218	74.18	121621	73.141	116701	75.02	113788	75.3	108515	75.22
Total	168795	100.00	166283	100	155564	100.00	151027	100	144256	100

The table above shows that on the last three years of generation, the average power generation in the Northern region was constituted for 25.9% of renewable based power projects and for 74.1% of thermal based power projects. In the Northern region, the low-cost must-run resources constitute less than 50% of the total grid generation. The simple operating margin is therefore selected as the appropriate method to calculate the OM emission factor. The commissioning dates come from various sources for all the plants located in the Northern region.

**Calculation of Baseline Emission Factor**

Referring to the guidelines in the section “Consolidated baseline methodology for grid-connected electricity generation from renewable sources” (ACM 0002), the baseline emission factor for UP (EF<sub>y</sub>) is calculated as a combined margin (CM), consisting of the combination of the operating margin (OM) and the build margin (BM) factors according to the following three steps:

STEP 1. Calculate the Operating Margin emission factor

STEP 2. Calculate the Build Margin emission factor





## STEP 3. Baseline Emission Factor

**Step 1: Calculation of Operating Margin Emission Factor for the region based on Simple OM**

The simple OM emission factor ( $EF_{OM, simple, y}$ ) is calculated as the generation-weighted average emissions per electricity unit ( $tCO_2/MU$ ) of all generating sources serving the system, not including low-operating cost and must-run power plants:

$$EF_{OM, y} = \frac{\sum Fi, j, y * COEFi, j, y}{\sum GENj, y}$$

where:

$Fi, j, y$  is the amount of fuel  $i$  (in a mass or volume unit) consumed by relevant power sources  $j$  in year(s)  $y$ ,

$j$  refers to the power sources delivering electricity to the grid, not including low-operating cost and must run power plants, and including imports to the grid,

$COEFi, j, y$  is the  $CO_2$  emission coefficient of fuel  $i$  ( $tCO_2 /$  mass or volume unit of the fuel), taking into account the carbon content of the fuels used by relevant power sources  $j$  and the percent oxidation of the fuel in year(s)  $y$ , and

$GENj, y$  is the electricity (MWh) delivered to the grid by source  $j$ .

The  $CO_2$  emission coefficient  $COEFi$  is obtained as:

$$COEFi = NCVi * EFCO2, i * OXIDi$$

where:

$NCVi$  is the net calorific value (energy content) per mass or volume unit of a fuel  $i$ ,

$OXIDi$  is the oxidation factor of the fuel

$EFCO2, i$  is the  $CO_2$  emission factor per unit of energy of the fuel  $i$ .

Mankapur Chini Mill has therefore adopted the ‘Simple OM’ method, and the simple OM emission factor is calculated using “3-year average statistics”

State	Generation GWh		
	2005	2004	2003
Delhi	11170.38	10593	8780
Haryana	9646.44	9792	8908
Himachal Pradesh	16020.29	11753	8735
Jammu & Kashmir	6405.24	7270	5983
Punjab	22087.95	25581	23690
Rajasthan	25933.43	23045	21861
Uttar Pradesh	73954.87	74345	73837
Uttaranchal	3577.23	3904	3770



Factor	2005	2004	2003
$\sum F_{i,j,y} \times COEF_{i,j}$ (tons/year)	142011855	138597138	133070105
$\sum GEN_{i,j}$ (MU)	125218	121621	116701
$\sum EF_{OM,y}$ (tCO <sub>2</sub> /yr)	1134	1139.6	1140
Average $\sum EF_{OM,y}$	1137.9 tCO <sub>2</sub> / GWh		

**Step 2: Calculation of Build Margin Emission Factor for the region (ex-ante):**

The project developer has adopted option 1 (ex-ante), which requires to calculate the Build Margin emission factor  $EF_{BM,y}$  ex-ante based on the most recent information available on plants already built for sample group  $m$  at the time of the PDD submission. The following data is used to determine the simple BM emission factor ( $EF_{BM,y}$ ):

$$EF_{BM,y} = \frac{\sum F_{i,m,y} * COEF_{i,m}}{\sum GEN_{m,y}}$$

where:

$F_{i,m,y}$  and  $COEF_{i,m}$  are analogous to the variables described for the simple OM method above for plants  $m$ .

A	20% of grid (MU)	33759
B	Plants meeting 20% (MU)	34041
C	Last Five Plants Total (MU)	12432

For the MCM project, the sample group  $m$  that consists of (b) the power plants capacity additions in the electricity system that comprise 20% of the system generation and that have been built most recently is adopted. Below is a list of power plants that comprises 20% of the system generation and which have been built most recently.

Power Plants	Fuel	Generation (GWh) 2005	Emission factor IPCC tCO <sub>2</sub> /GWh	Emissions tCO <sub>2</sub> 2005	Year of Commission
Pragati CCGT	Gas HBJ	2550.7	687	1751935	2003
Chamera II	Hydro	1347.3	0	0	2003
Naptha Jhakri	Hydro	5109.48	0	0	2003
Kota	Coal 4F	1470	1168	1717075	2003
Suratgarh	Coal 2W	1955	1074	2100409	2003
Ramgharh ST	Gas HBJ	17	687	11676	2003
Baspa	Hydro	1193.16	0	0	2002



Upper sindh	Hydro	177.45	0	0	2002
Sewa	Hydro	10.17	0	0	2002
Suratgharh	Coal 2W	1951	1074	2096111	2002
Ramgharh GT	Gas HBJ	342.93	687	235540	2002
Panipat	Coal 4F	1482	1463	2168290	2001
Malana	Hydro	269.66	0	0	2001
Chenani	Hydro	77.33	0	0	2001
Suratgharh	Coal 2W	1876	1074	2015533	2001
F'Bad CCGT	Gas HBJ		484		2000
Ghanvi	Hydro	74.08	0	0	2000
Ranjit sagar	Hydro	1144.56	0	0	2000
Suratgharh	Coal 2W	1704	1074	1830740	2000
RAPS	Nuclear	1470	0	0	2000
RAPS	Nuclear	1649	0	0	2000
Tanda	Coal 4F	809	1844	1491700	2000
Tanda	Coal 4F	841	1844	1550704	2000
Tanda	Coal 4F	836	1844	1541484	2000
Tanda	Coal 4F	832	1844	1534109	2000
F'Bad CCGT	Gas HBJ	3161.9	484	1528889	1999
Unchahar	Coal 3E	1690	1168	1974053	1999

$\sum Fi_{i,j,y} \times COEF_{i,j}$ (tons/year)	23548247
$\sum GEN_{i,j}$ (MU)	34041
$\sum EF_{BM,y}$ (tCO <sub>2</sub> /yr)	691.77

**Step 3 Baseline Emission Factor (EF<sub>y</sub>)**

The baseline emission factor EF<sub>y</sub> is calculated as the weighted average of the Operating Margin emission factor (EF<sub>OM,y</sub>) and the Build Margin emission factor (EF<sub>BM,y</sub>), where the weights W<sub>OM</sub> and W<sub>BM</sub>, by default, are 50%, and EF<sub>OM,y</sub> and EF<sub>BM,y</sub> are calculated as described in steps 1 and 2 above and are expressed in tCO<sub>2</sub>/MU.

$$EF_{grid,y} = 0.5(EF_{OM,y} + EF_{BM,y})$$

$\sum EF_{BM,y}$	691.77 tCO <sub>2</sub> e/ GWh
$\sum EF_{OM,y}$	1137.99 tCO <sub>2</sub> e/ GWh
$\sum EF_y$ (Avg of OM & BM)	<b>914.88 tCO<sub>2</sub>e/Gwh</b>



#### Annex 4

### MONITORING INFORMATION

The Monitoring and Verification (M&V) procedures define a project-specific standard with which the project's performance (i.e. GHG reductions) and conformance on all relevant criteria is to be monitored and verified. It includes developing suitable data collection methods and data interpretation techniques for the monitoring and verification of GHG emissions with a specific focus on technical/efficiency/performance parameters. It also allows for the review, scrutiny and benchmark of all this information for conformity with the reports that pertain to M & V protocols.

The M & V Protocol provides a range of data measurement, estimation and collection options/techniques for each case, indicating the preferred options consistent with good practices, to allow project managers and operational staff, auditors, and verifiers to apply the most practical and cost-effective measurement approaches to the project. The aim is to enable promoters of the project activity to have a clear, credible and accurate set of monitoring, evaluation and verification procedures. The purpose of these procedures would be to direct and support continuous monitoring of project performance/key project indicators to determine project outcomes and greenhouse gas (GHG) emission reductions.

The project revenue is based on the units generated, which are measured by power meters at the plant. The monitoring and verification system mainly comprise of these meters as far as power for auxiliaries and export is concerned. The biomass, as an input, is also to be monitored. The measurement of the quantity of biomass used will produce evidence that the energy is being generated with zero net CO<sub>2</sub> emissions.

The project activity employs the latest state of art monitoring and control equipment that measures, records, reports, monitors and controls various key parameters. Parameters monitored are the quantity and the quality of the biomass fuel used, total power generated, power for auxiliary purposes, CO<sub>2</sub> content in the flue gas, oxygen content in flue gas, particulate matter emissions from the project, etc. The monitoring and controls will be part of the Distributed Control System (DCS) of the entire plant. All monitoring and control functions will be done as per the internally accepted standards and norms of the plant.

The instrumentation system of the project activity will mostly comprise of microprocessor – based instruments of reputed make with the desired level of accuracy. All instruments will be calibrated and marked at regular intervals so that the accuracy of measurement can be ensured at all times.

The emission reductions from the project activity mainly depend on the project emissions of GHG sources and the baseline emissions, and are due to the displacement of fossil fuel generated electricity in the grid system.

### GHG SOURCES

#### 1. Project Emissions from the use of fossil fuel



There is no fossil fuel combustion associated with the project activity. Hence there is no project emissions associated to fossil fuel combustion due to the MCM project activity implementation. Therefore project emissions due to the fossil fuel combustion have not been considered.

### **2. Project Emissions from transportation of biomass**

There is no fossil fuel combustion for transportation of bagasse. Bagasse is mill-generated biomass.

### **3. Project Emissions from the burning of biomass**

Project emissions arise from the burning of bagasse in the boiler.

### **4. Baseline Emissions due to the displacement of grid electricity**

As the number of units generated by the plant and displaced fossil fuel generated electricity from the grid determines the emission reductions from the project, it becomes important for the project to monitor the net units generated on real time basis. The net electricity multiplied by the baseline emission factor gives the baseline emission reductions.

## **PROJECT PARAMETERS AFFECTING EMISSION REDUCTIONS**

### **Monitoring Approach**

The general monitoring principles are based on:

- Frequency
- Reliability
- Registration and reporting

### **Frequency of monitoring**

The project developer has installed all metering and check metering facilities within the plant premises. The measurement will be recorded and monitored on a continuous basis by the project developer through the DCS.

### **Reliability**

The amount of emission reductions is proportional to the net energy generation from the project. Thus the final KWh meter reading is the final value from the project side. All measurement devices are microprocessor based, the best accuracy is procured from the reputation of the microprocessor manufacturers. Since the reliability of the monitoring system is governed by the accuracy of the measurement system and the quality of the equipment to produce the result, all power-measuring instruments are calibrated once a year to ensure the system's reliability. All instruments carry tag plates, which indicate the date of calibration and the date of the next calibration. The system ensures that the final generation data is highly reliable.

### **Registration and reporting**

The registration of data will be done on-line, in the control cabin, through a microprocessor. However, hourly data will be logged in in addition to the software memory. Daily, weekly and monthly reports stating the generation data will be prepared. In addition to the records maintained by the plant promoters, monitors will establish the power generated by the project and certify the compliance of the data.



The other major factors which need to be ensured and monitored are: the use of biomass fuel for power generation, the power for the plant, the power for auxiliary purposes and the parameters that would ensure the smooth and regular operation of the cogeneration. No other project- specific indicators that could affect the emission reductions claims have been identified.

## **BAGASSE REQUIREMENTS AND UTILIZATION**

### **Availability of bagasse**

The major fuel used by the cogeneration power plant is bagasse. Bagasse is supplied to the cogeneration plant after sugar processing. The production of electricity will mainly depend on the biomass fed to the boiler.

### **Quantity of biomass fuel used in the boiler**

The biomass from the sugar plant will be first dumped in the fuel storage area from where it will be taken to the fuel processing machinery with the help of belt conveyors. Once the fuel processing machinery processes the fuel, it will be taken to boiler bunkers with the help of belt conveyors, and from there the fuel will finally enter the boiler.

The belt conveyors, which bring the fuel from the processing machinery to the boiler bunkers, consist of a metal detector, a tramp iron detector, a magnetic separator and an online weighing system. The metal detector, tramp iron separator etc. will prevent any metal particles from entering into the boiler and ensure that only fuel is conveyed to the boiler. An online weighing system provided to the belt conveyors measures, records and transmits the actual quantity of fuel entering the boiler for the online monitoring in the DCS. The weighing system will be calibrated regularly to ensure the accuracy of the measurement. The data will be recorded for further verification.

The fuel proposed for the power generation is bagasse. The properties of this biomass fuel like ultimate analysis, calorific value, ash composition etc. are already established and will be consistent in the region. Nevertheless, it is proposed to monitor the various properties of the biomass fuels by taking samples at random from the fuel lots of processed fuel so that in case of any drastic change in the properties, corrective actions can be taken. The measurement of fuel properties like ultimate analysis, calorific value etc. will be done at reputed laboratories as per international practices and the data or documents will be kept open for verifiers. The data will also be computerized and monitored through the management information system of the DCS.

## **OPERATIONAL PARAMETERS OF THE PROJECT ACTIVITY**

### **Total Power Generated**

The total power generated by the power project will be measured in the plant premises with the best accuracy and will be recorded and monitored on a continuous basis through the DCS.

### **Power consumed by the plant auxiliaries**

The power consumed by plant auxiliaries will be recorded in the plant premises with the best accuracy. The total quantum of power consumed by the auxiliaries would affect the total power exported to the grid and thus the amount of GHG reductions. Therefore, any increase in the consumption pattern of the auxiliary system will be attended to.



**Power consumed by the plant**

The power exported to grid will be recorded in the plant premises with the best accuracy. The total quantum of power consumed by the plant would affect the total power to the exported to the grid and thus the amount of GHG reductions. Therefore, any increase in the consumption pattern will be attended to.

All the above parameters/factors will demonstrate the performance of the project at any point of time.

**Verification**

The performance of the biomass based power project leads to CO<sub>2</sub> emission reductions. In other words, the longer the cogeneration power plant runs, generating power, the more emission reductions there are. The project control system comprises a state of the art sophisticated control and monitoring system like the Distributed Control System. It measures and collects the information on various process parameters, records, monitors and controls on a continuous basis. Fully functional management information systems were built in the DCS so that the access and verification of actual data is possible at all times. The major activities to be verified are as under:

- Verification of various measurement and monitoring methods
- Verification of instrument calibration methods
- Verification of data generated by the DCS
- Verification of measurement accuracy

The following major project parameters need to be verified, based on the available operating data, as they can affect the emission claims:

- The cane crushing by sugar unit
- The quantity of bagasse
- The efficiency of project activity
- The total generation of power, the captive and auxiliary power requirements, the power export to the grid

-----